

# NUMERICAL STUDIES OF CONCRETE PLATES UNDER LOCALIZED BLAST LOADS

SOFIA W. ALISJAHBANA<sup>1</sup>, WIRATMAN WANGSADINATA<sup>2</sup>, and IRENE  
ALISJAHBANA<sup>3</sup>

<sup>1</sup>*Civil Engineering Dept, Bakrie University, Jakarta, Indonesia*

<sup>2</sup>*Wiratman and Associates, Consulting Engineering, Jakarta, Indonesia*

<sup>3</sup>*Civil Engineering Dept, Universitas Indonesia, Depok, Indonesia*

An investigation has been carried out to examine the dynamic behavior of concrete plates subjected to localized blast loading. The concrete plate is modeled as a thin plate with finite dimensions sitting on an elastic three-parameter soil foundation model. The localized blast loading is expressed by using the Dirac Delta function for different value of the load's position. The governing equation of the problem is solved using the modified Bolotin method for determining the natural frequencies and the wave numbers of the system. The orthogonal properties of Eigen functions are used to find the general solution of the problem. Special emphasis is focused on the mid-point displacements. The results obtained allow an insight into the effect of the load's position, the thickness of the concrete plate on the response of the concrete plate under localized blast loading and indicate that the load's position and the thickness of the plate can affect their overall behavior.

*Keywords:* Dynamic behavior, Localized blast load, Dirac delta function, Three-parameter soil foundation, Natural frequencies, Eigen function.

## 1 INTRODUCTION

In recent years, public buildings and structures have unexpectedly been exposed to the risk of terrorist attacks, particularly in the form of vehicle bombing or other portable detonation devices. These potential threats give rise to a challenging question of structural safety, provided that any structural part could be subjected to unpredictable loading that were not primarily designed against, in terms of both the loading type and intensity.

The dynamic analysis of orthotropic plates with fully fixed supported boundary conditions under localized blast loading was presented by Alisjahbana and Wangsadinata in 2014. Effects of various parameters such as the position of the blast loading, plate thickness and damping ratio on the maximum dynamic deflection of the plates subjected to localized blast loading were considered (Alisjahbana and Wangsadinata 2014). In most models used previously, the dynamic response of concrete plate is taken into account only by the inertia of the plate (Lu 2001). Concerning the soil, inertia is neglected in dynamic modeling of pavement structure. To extend the previous work, the present study investigates dynamic response of concrete pavement resting on Pasternak foundation under localized blast loading. The concrete pavement is modelled as a thin orthotropic plate with semi rigid boundary condition in its edges. In order to take into account its inertia, the soil is modelled as a three-parameter type (Gibigaye *et al.* 2016).

## 2 GOVERNING EQUATION

In this research work, a rectangular orthotropic concrete plate of thickness  $h$  sits on an elastic three-parameter soil foundation model as shown in Fig. 1 is considered. According to the classic theory of thin plates and taking into account the reduced mass of soil, the transverse deflection of the Kirchhoff plate satisfies the following differential equation (Gibigaye *et al.* 2016):

$$D_x \frac{\partial^4 w(x, y, t)}{\partial x^4} + 2B \frac{\partial^4 w(x, y, t)}{\partial x^2 \partial y^2} + D_y \frac{\partial^4 w(x, y, t)}{\partial y^4} - G_s \left( \frac{\partial^2 w(x, y, t)}{\partial x^2} + \frac{\partial^2 w(x, y, t)}{\partial y^2} \right) + \gamma h \frac{\partial w(x, y, t)}{\partial t} + (\rho h + m_0) \frac{\partial^2 w(x, y, t)}{\partial t^2} = p(x, y, t) \quad (1)$$

where,  $w(x, y, t)$  is the deflection of the plate which is equal to the deflection of the plate-soil interface,  $D_x$  is the flexural rigidity of plate in the  $x$ -direction,  $B$  is the torsional rigidity of the plate,  $D_y$  is the flexural rigidity in the  $y$ -direction,  $G_s$  is the shear modulus of the foundation,  $\gamma$  is the logarithmic decrement of the soil,  $\rho$  is the mass density of the plate,  $m_0$  is the inertial factor of the foundation soil.

## 3 IDEALISATION OF BLAST LOADING

Determination of the exact localized blast loadings is almost unrealistic considering the complicated process of the interaction of the blast wave with the target in concern (Li *et al.* 2009). In order to reduce this complex problem of blast loadings to reasonable terms, Alisjahbana and Wangsadinata have suggested a simplified blast loading function as a stepped triangular function as shown in Fig. 2 (Alisjahbana and Wangsadinata 2011):

$$P(t) = P_0 \left( 1 - \frac{t}{td_3} \right) \text{ for } 0 \leq t \leq td_1; \quad P(t) = P_2 \left( 1 - \frac{t}{td_2} \right) \text{ for } td_1 \leq t \leq td_2; \quad P(t) = 0 \text{ for } t > td_2 \quad (2)$$

where,  $P_0$  and  $P_2$  are the maximum amplitude of the blast loading,  $td_1$ ,  $td_2$  and  $td_3$  are duration of the blast loading.

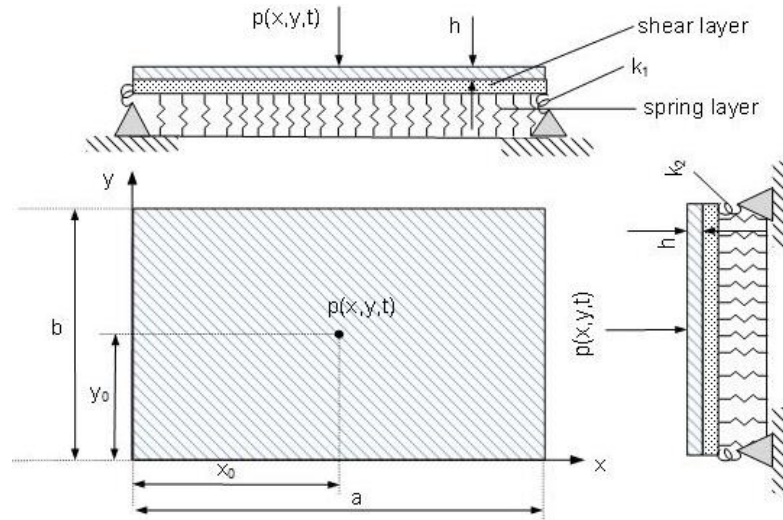

Figure 1. An elastic rectangular concrete plate resting on an elastic three-parameter soil foundation.

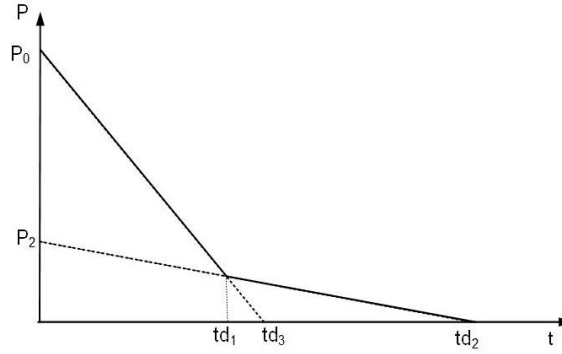

Figure 2. Model of a stepped triangular blast loading.

#### 4 DETERMINATION OF THE EIGEN FREQUENCIES

In order to solve the governing equation (1) of the problem, the free vibrations solution of the problem is set as:

$$w(x, y, t) = \sum_{m=1}^{\infty} \sum_{n=1}^{\infty} W_{mn}(x, y) \cos(\omega_{mn} t) \quad (3)$$

$\omega_{mn}$  is the circular frequency of plate and  $W_{mn}(x, y)$  is the function of position coordinates determined for the mode numbers  $m$  and  $n$  in  $x$ -direction and  $y$ -direction, respectively, which can be determined from the first and second auxiliary Levy-type problem (Alisjahbana and Wangsadinata 2014).

##### 4.1 First Auxiliary Levy-type Problem

Based on the Modified Bolotin Method the solution of Eq. (1) for the first auxiliary problem can be expressed as (Alisjahbana and Wangsadinata, 2011)

$$W(x, y) = \sum_{m=1}^{\infty} \sum_{n=1}^{\infty} X_{mn}(x) \sin\left(\frac{q\pi y}{b}\right) \quad (4)$$

Satisfying the semi rigid boundary conditions along  $x=0$  and  $x=a$ :

$$X_{mn}(x) = 0 ; -D_x \left( \frac{\partial^2 W(x, y)}{\partial x^2} + \nu y \frac{\partial^2 W(x, y)}{\partial y^2} \right) = k_1 \frac{\partial W(x, y)}{\partial x} \text{ at } x=0 \text{ and } x=a \quad (5)$$

Substituting Eq. (4) into the homogeneous form of Eq. (1) results in the Eigen mode of the plate in the  $x$ -direction  $X_{mn}(x)$ :

$$X_{mn}(x) = \cosh\left(\frac{\beta\pi}{ab} x\right) + \left( \frac{bpk_1(c_1 - C_1) + a(F_1 + F_2)s_1}{k_1(bpS_1 - \beta s_1)} \right) \sinh\left(\frac{\beta\pi}{ab} x\right) - \cos\left(\frac{p\pi}{a} x\right) + \left( \frac{ab(F_1 + F_2)S_1 + \beta k_1(c_1 - C_1)}{k_1(\beta s_1 - bpS_1)} \right) \sin\left(\frac{p\pi}{a} x\right) \quad (6)$$

where:

$$\beta = \sqrt{\frac{2Bq^2a^2}{D_x} + p^2b^2 + \frac{G_s a^2 b^2}{\pi^2 D_x}}; F_1 = D_x \left(\frac{\beta}{ab}\right)^2 \pi - \nu_y D_x \left(\frac{q}{b}\right)^2 \pi; F_2 = D_x \left(\frac{p}{a}\right)^2 \pi + \nu_y D_x \left(\frac{q}{b}\right)^2 \pi;$$

$$C_1 = \cosh\left(\frac{\pi\beta}{b}\right); c_1 = \cos(p\pi); S_1 = \sinh\left(\frac{\pi\beta}{b}\right); s_1 = \sin(p\pi)$$

## 4.2 Second Auxiliary Levy-type Problem

The solution of Eq. (1) for second auxiliary problem that satisfies the boundary conditions of

$$Y_{mn}(y) = 0; -D_y \left(\frac{\partial^2 W(x, y)}{\partial y^2} + \nu_x \frac{\partial^2 W(x, y)}{\partial x^2}\right) = k_2 \frac{\partial W(x, y)}{\partial y} \text{ at } y=0 \text{ and } y=b \quad (7)$$

can be expressed as

$$W(x, y) = \sum_{m=1}^{\infty} \sum_{n=1}^{\infty} Y_{mn}(y) \sin\left(\frac{p\pi x}{a}\right) \quad (8)$$

Substituting Eq. (8) into the homogeneous form of Eq. (1) results in the Eigen mode of the plate in the y-direction  $Y_{mn}(y)$ :

$$Y_{mn}(y) = \cosh\left(\frac{\theta\pi y}{ab}\right) + \frac{a(s_2 b(F_3 + F_4) + qk_2(c_2 - C_2))}{k_2(S_2 qa - s_2\theta)} \sinh\left(\frac{\theta\pi y}{ab}\right) - \cos\left(\frac{q\pi y}{b}\right)$$

$$+ \frac{(S_2 ab(F_3 + F_4) + k_2\theta(c_2 - C_2))}{k_2(\theta s_2 - S_2 qa)} \sin\left(\frac{q\pi y}{b}\right) \quad (9)$$

where:

$$\theta = \sqrt{\frac{2Bp^2b^2}{D_y} + q^2a^2 + \frac{G_s a^2 b^2}{\pi^2 D_y}}; F_3 = \left[ D_y \left(\frac{\theta}{ab}\right)^2 \pi - \nu_x D_y \left(\frac{p}{a}\right)^2 \pi \right];$$

$$F_4 = \left[ D_y \left(\frac{q}{b}\right)^2 \pi + \nu_x D_y \left(\frac{p}{a}\right)^2 \pi \right]; C_2 = \cosh\left(\frac{\pi\theta}{a}\right); c_2 = \cos(q\pi); S_2 = \sinh\left(\frac{\pi\theta}{a}\right); s_1 = \sin(q\pi)$$

The unknown quantities  $p$  and  $q$  are calculated from the transcendental equation as:

$$-2a^2b^3k_1^2p\beta + 2ab^3k_1^2p\beta \cos[p\pi] \cosh\left[\frac{\pi\beta}{b}\right] +$$

$$+ \left( a^2b^2k_1^2(b^2p^2 - \beta^2) + D_x^2\pi^2(b^2p^2 + \beta^2)^2 \sin[p\pi] \sinh\left[\frac{\pi\beta}{b}\right] \right) = 0 \quad (10a)$$

$$-2a^3b^2k_2^2q\theta + 2a^3bk_2^2q\theta \cos[q\pi] \cosh\left[\frac{\pi\theta}{a}\right] + a^4(b^2k_2^2q^2 + D_y\pi^2q^4)$$

$$+ a^2 \left( (-b^2k_2^2 + 2D_y^2\pi^2q^2)\theta^2 + 2D_y^2\pi^2\theta^4 \right) \sin[q\pi] \sinh\left[\frac{\pi\theta}{a}\right] = 0 \quad (10b)$$

Once the value of  $p$  and  $q$  are determined from Eqs. (10a)-(10b), the Eigen modes of the system are determined as the product of Eq. (6) and Eq. (7). The natural frequency of the system can be expressed as:

$$\omega_{mn}^2 = \frac{\pi^4}{\rho h + m_0} \left[ D_x \left(\frac{p}{a}\right)^4 + 2B \left(\frac{pq}{ab}\right)^2 + D_y \left(\frac{q}{b}\right)^4 \right] + \frac{k_f}{\rho h + m_0} + \frac{G_s}{\rho h + m_0} \left[ \left(\frac{p\pi}{a}\right)^2 + \left(\frac{q\pi}{b}\right)^2 \right] \quad (11)$$

### 4.3 Determination of the Time Function

The time function that satisfies Eq. (1) can be expressed as:

$$\ddot{T}_{mn}(t) + 2\xi\omega_{mn}\dot{T}_{mn}(t) + \omega_{mn}^2 T_{mn}(t) = \frac{\int_0^a X_{mn}(x)dx \int_0^b Y_{mn}(y)dy}{(\rho + m_0)Q_{mn}} P(t)\delta[x - x(t)]\delta[y - y(t)] \quad (12)$$

where  $\delta[\cdot]$  is the Dirac Delta function and  $Q_{mn}$  is the normalization factor of the Eigen modes that can be expressed as:

$$Q_{mn} = \int_0^a (X_{mn})^2 dx \int_0^b (Y_{mn})^2 dy \quad (13)$$

## 5 NUMERICAL APPLICATIONS, RESULTS AND DISCUSSION

Using the procedure described above, an orthotropic concrete plate on the inertial type of soil subjected to a localized blast loading is analyzed. In this paper, a finite rectangular concrete plate is considered. The structural properties of the plate are the size (4 m x 3 m); the thickness of 0.12 m, the physical characteristics of the plate are  $\rho = 2400 \text{ kg.m}^{-3}$ ;  $\nu_x = 0.2$ ;  $\nu_y = 0.3$ ;  $k_1 = 8.5 \cdot 10^7 \text{ Nm/rad/m}$ ;  $k_2 = 4.75 \cdot 10^7 \text{ Nm/rad/m}$ ;  $E_x = 27.8 \cdot 10^9 \text{ Pa}$ ;  $E_y = 30 \cdot 10^9 \text{ Pa}$ ;  $m_0 = 1261.63 \text{ kg.m}^{-3}$ . The stepped triangular blast loading magnitude are  $P_0 = 12 \cdot 10^4 \text{ N}$ ;  $P_2 = 3 \cdot 10^4 \text{ N}$ ;  $td_1 = 2.293 \cdot 10^{-3} \text{ s}$ ;  $td_2 = 40 \cdot 10^{-3} \text{ s}$ ;  $td_3 = 3 \cdot 10^{-3} \text{ s}$ .

### 5.1 Variation of Deflection as a Function of Blast Loading Position

Figure 3 shows the variation of dynamic deflection as a function of blast loading position for soft soil condition ( $H_s = 5 \text{ m}$ ). The maximum dynamic deflection at the mid-span occurred when the position of the blast loading occurred at  $(a/8, b/2)$  and  $0 \leq t \leq td_1$ . This result indicates that the maximum dynamic deflection is influenced by the position of the blast load and the duration of the blast load.

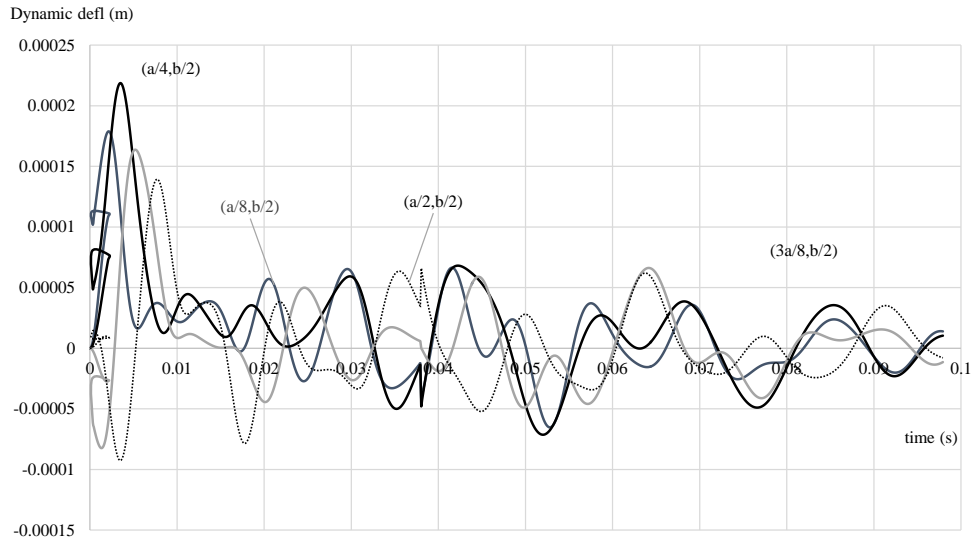

Figure 3. Dynamic deflection time history of concrete plate for different blast load's position.

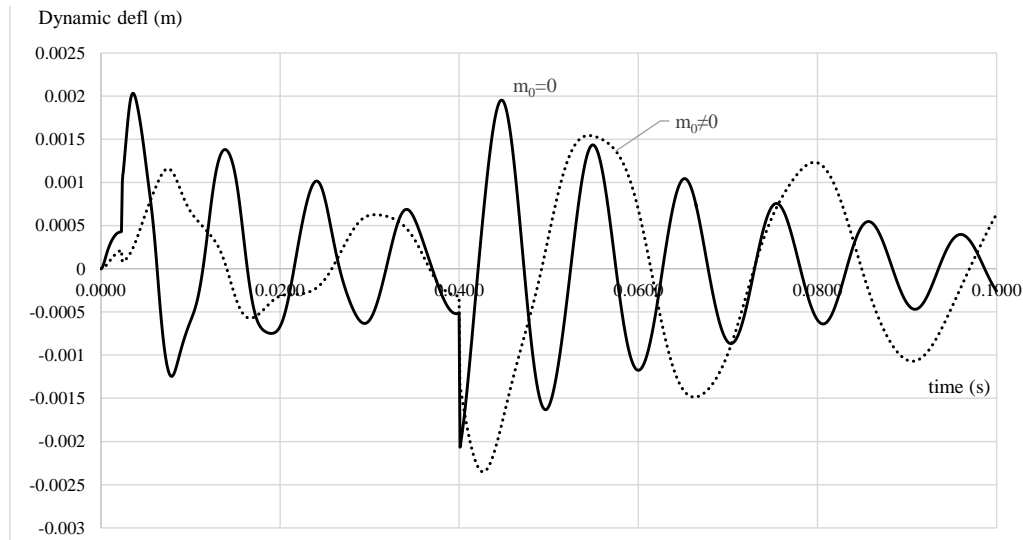

Figure 4. Dynamic deflection time history of concrete plate as the function of inertial soil ( $m_0$ ).

## 5.2 Effect of Inertial Soil Factor on Dynamic Deflection

Figure 4 shows the variations of the deflection at the center of the mid-span of the plate for 2 types of foundation models. It can be seen that by including the inertial soil factor ( $m_0$ ) into the equation of motion, the maximum dynamic deflection can be reduced by 14.6% compared with the maximum dynamic deflection of the plate on Pasternak foundation model.

## 6 CONCLUSION

In this paper the dynamic behavior of the orthotropic plate with semi rigid boundary condition subjected to stepped triangular blast loading was studied. The position of the blast loading, the duration of the blast load and the effect of inertial soil factor, which may affect the dynamic response of the plates subjected to blast loading was considered. The position of the blast loading is found to influence the development of maximum response. The three type parameters of foundation model will significantly reduce the maximum dynamic deflection.

## References

- Alisjahbana, S.W. and Wangsadinata, W., Response of Damped Orthotropic Plates Subjected to a Stepped Triangular Blast Loading, *The Twelfth East Asia-Pacific Conference on Structural Engineering and Construction*, Procedia Engineering 14, 115-120, 2011.
- Alisjahbana, S.W. and Wangsadinata, W., Numerical Dynamic Analysis of Orthotropic Plates under Localized Blast Loads, *Sustainable Solutions in Structural Engineering and Construction*, 115-120, Bangkok, Thailand, 2014.
- Gibigaye, M., Yabi, C. P., Alloba, I. E., Dynamic Response of a Rigid Pavement Plate Based on an Inertial Soil, *International Scholarly Research Notices*, Volume 2016, Article ID 4975345, 2016.
- Li, B., Pan, Tso-Chien, Nair, A., A Case Study of the Effect of Cladding Panels on the Response of Reinforced Concrete Frames subjected to Distant Blast Loadings, *Nuclear Engineering and Design*, 239, 455-469, 2009.
- Lu, S., Dynamic Displacement Response of Beam-type Structures to Moving Line Loads, *International Journal of Solids and Structures*, Vol. 38, No. 48-49, 8869-8878, 2001.